

Axis^{AX}

Axis AX Single Loop Fire Alarm Control Panel

The AX-CTL-1C is a small, compact single-loop fire alarm control panel for use in cost-sensitive fire alarm installations, where fewer than 126 addressable points are required. The panel contains the same features as the Advanced AX-CTL-1L, AX-CTL-2 and AX-CTL-4 intelligent fire alarm control panels but in a smaller, compact enclosure.

As part of the Axis AX range, the AX-CTL-1C can be easily used in larger applications due to its optional peer-to-peer networking capabilities.

Designed with installation and service engineers in mind, the AX-CTL-1C is modularly packaged, using surface mount and dual flash microprocessor technology, with onboard real-time clocks for ease of installation, troubleshooting, programming and maintenance.

The AX-CTL-1C provides a single Class X, A or B signalling line circuit (SLC). Communication to the field devices attached to the SLC is via an advanced, 100% digital protocol which has the advantages of being highly immune to noisy environments. The SLC supports up to 126 analogue-addressable devices (any combination of intelligent detectors, input and/or output devices, including loop-powered technology devices). In addition, unique sub-addressing of various input and/or output devices is permitted to expand on the overall AX-CTL-1C system capacity.

The AX-CTL-1C comes with two filtered, voltage-regulated notification appliance circuits (NACs), Class A or B, each rated 2 Amp @ 24 VDC. Due to exceptional regulation and high rating, the onboard NAC outputs provide compatibility with most listed notification appliance devices.

The AX-CTL-1C has resettable and non-resettable power outputs; each rated 0.5 Amp @ 24 VDC for connection to four-wire conventional smoke detectors and/or ancillary devices. Each AX-CTL-1C contains three field-programmable, Form "C" relay contacts rated 1 Amp @ 30 VDC, defaulted as a fail-safe trouble relay, alarm relay and supervisory relay.

Simplifying and reducing initial system set-up, each AX-CTL-1C panel is equipped with an installer-friendly "auto-learn/loop detection" feature that permits the rapid recognition of all signalling line circuit devices. This rapid recognition simplifies the immediate assignment of critical life safety functions. Assignments include: intelligent detector type and operation criteria, addressable input device recognition as an alarm input and addressable output control on a general alarm basis.



Features

- 126 analogue-addressable points
- Advanced user interface w/graphical LCD
- "Dynamix" I/O relationship programming
- Synchronised audible and visual NAC circuits
- Superior service & maintenance diagnostics
- Peer-to-peer networking
- Automatic drift compensation per detector
- Automatic detector testing with maintenance alert
- Alarm verification and PAS.
- Class X, A or B SLC operation (supports loop-powered technology)
- Class A or B NAC circuits
- Voltage-regulated NACs (compatible with most listed NAC devices)
- Multi-pattern and two-stage NAC control

Designed with built-in powerful installation and customisation tools, the AX-CTL-1C can adapt to virtually any application requirement. With Dynamix programming, time-consuming complexities associated with I/O relationship programming such as two-stage multi-pattern NAC control, intelligent detector drift compensation, precision response/sensitivity mode settings, flexible timing functions and more are significantly reduced.

The AX-CTL-1C is fully field programmable via the onboard graphical LCD display and alphanumeric keypad. Front panel programming may encompass defining input to output relationships, configuring output circuit characteristics, entering zone, device, and other text descriptions, and configuring multiple user-access level passwords.

To maximise the capability and flexibility of the single loop fire alarm control panel, the standard Advanced Windows-based PC-NeT field configuration tool is compatible with the AX-CTL-1C. The PC-NeT field configuration tool is a powerful, user-friendly programming tool that allows users to perform virtually any I/O relationship with multiple criteria. Simple drop-down menus with point-and-click operation make project commissioning and troubleshooting fast and efficient.

The AX-CTL-1C can accommodate remote graphical LCD annunciators (with or without system control capabilities) on the Ad-NeT- Plus peer-to-peer network. Multiple annunciator locations can be created based on installation demands. These locations can have either: no system control, partial system control, or full system control. When installations exceed a single panel's capacity, the Advanced Ad- NeT-Plus peer-to-peer network can be implemented, providing up to 200 network nodes. The Ad-NeT-Plus is completely field programmable for inter-panel functionality or segregation of information and control based on installation requirements.

Features (continued)

- Network-wide audible and visual synchronisation
- "Auto-learn/loop detection" programming
- Built-in intelligent multi-meter

Listings and Approvals

- Certified to UL864 10th Edition – File No. **S35979**
- CSFM Approved: Pending
- NYCFD COA: Pending

Designed with the technician in mind, each module of the AX-CTL-1C single loop fire alarm control panel is easy to install and service.

The integral power supply offers status LEDs, temperature-compensated charging, and the ability to operate directly from the batteries when AC supply is not yet available at the installation site. A unique built-in intelligent multi-meter allows technicians to interrogate any input and/or output and diagnose potential time consuming trouble issues with virtually no complications or aggravation.



Advanced User Interface w/Graphical LCD:

Designed to be user-friendly and easy to operate, the Advanced User Interface w/Graphical LCD (backlit 240 x 64) is the information and control center for the AX-CTL-1C single loop fire alarm control panel.

The unit incorporates a graphical LCD display, LED status indicators, control buttons (including 3 programmable buttons), navigation buttons, and a 12 button keypad for complete system status, interrogation, and control.

Button (Keys)

| | |
|--|---|
| | Reset |
| | Ack (panel buzzer acknowledge) |
| | Resound (resound signals) |
| | Silence (silence signals) |
| | Fire Drill |
| | Function Keys (3 - programmable control buttons) |
| | Navigation Keys (up, down, left, right, and tick [enter]) |
| | 12 Button Keypad (numbers, letters, esc, and menu) |

LED Indicators

| | |
|-----------------------|--------|
| Alarm | Red |
| Pre-Alarm | Red |
| Disable | Yellow |
| Test | Yellow |
| P.A.S. | Yellow |
| Power | Green |
| Supervisory | Yellow |
| NAC Silenced | Yellow |
| NAC Trouble | Yellow |
| NAC Disabled | Yellow |
| System Trouble | Yellow |
| Programming | Yellow |
| Programmable LED 1 | Red |
| Programmable LEDs 2-5 | Yellow |

Wiring Diagram

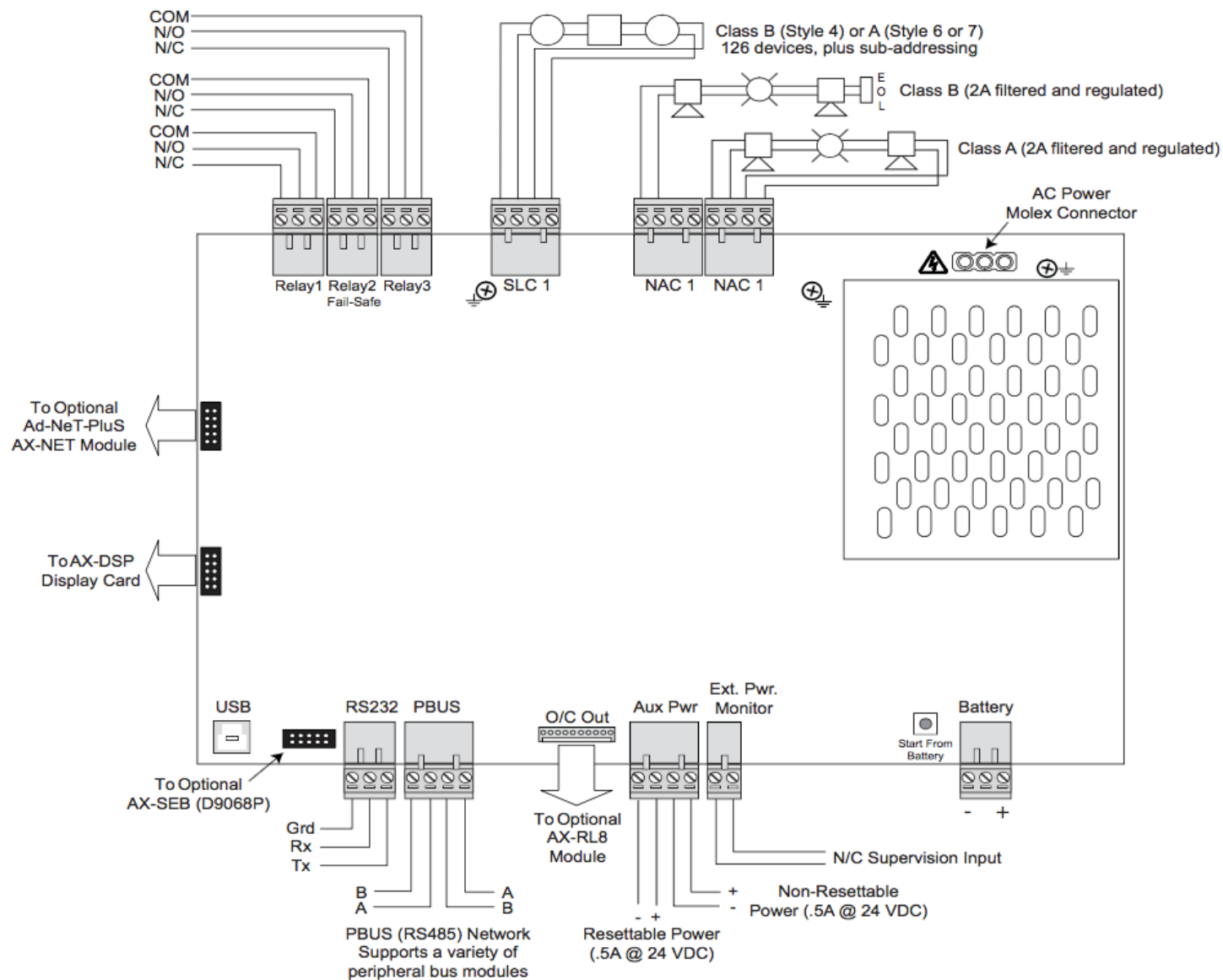

Specification

| | | |
|---------------------------------------|--|--------|
| Operating Voltage | 120 VAC (1.4A) - 240 VAC (0.7A), 50/60Hz | |
| System-Brown-Out | 98 VAC nominal | |
| Battery Circuit | | |
| Charging Voltage | 27.4 VDC nominal* | |
| Temp. Compensated Charging Current | 2.3 Amp | |
| Battery Derating Factor | 0.83A | |
| Battery Capacity | 7 Ah (minimum), 75 Ah (maximum) | |
| Battery Fuse | 5A @ 240 VAC, time delayed, ceramic, high breaking (in-line wire link) | |
| Fire, Supervisory, and Trouble Relays | (Power limited - when using system power) | |
| Type | Form "C" | |
| Rating | 1A @ 30 VDC/VAC | |
| Trouble Relay | Normally active (fail-safe operation) | |
| Auxiliary Power Outputs | (Power limited) | |
| Resettable | | |
| Voltage | 24 VDC | |
| Current | 0.5A | |
| Reset Time | 10-15 seconds | |
| Non-Resettable | | |
| Voltage | 24 VDC | |
| Current | 0.5A | |
| Humidity | 85% RH | |
| Temperatures | | |
| Operating | 32 °F - 120 °F (0 °C - 49 °C) | |
| Recommended Room | 60 °F - 86 °F (15 °C - 27 °C) | |
| Enclosure Dimensions | 17 7/8"H x 14 3/4"W x 5 5/8"D | |
| SLC Loop | (Power limited) | |
| Class (Style) | Class X, A or B | |
| Voltage | 24 VDC | |
| Minimum Return Voltage | 17 VDC | |
| Current | 0.5A | |
| NAC Circuits | (Power limited) | |
| Class (Style) | Class A or B | |
| Voltage | 24 VDC (filtered and regulated) | |
| Minimum Return Voltage | 16 VDC | |
| Current | 2A (each) | |
| Maximum Voltage Drop | 3 VDC | |
| Maximum Line Impedance | 1.5Ω | |
| RS232 | Supervised, optically isolated | |
| Baud Rate | 9600 | |
| Parity | None | |
| Data Bits | 8 | |
| Stop Bits | 1 | |
| Base Card Operating Current | Quiescent | Alarm |
| AX-CTL-1PCB | 110 mA | 195 mA |

Refer to individual Axis AX Series module data sheets for specific specifications regarding optional modules.

*For use with listed/compatible product

Order Codes and Options

| | |
|---|---|
| AX-CTL-1C* | Single-Loop Fire Alarm Control Panel with power supply/charger, 1 SLC, 2 NACs, 3 auxiliary relays (enclosure supports batteries 7Ah - 18Ah) |
| AX-1C-BP* | Optional Battery Cover (Dress) Plate |
| <i>AX CTL Base Card Option Modules**:</i> | |
| AX-NET4 | Network Interface Card Class B |
| AX-NET7 | Network Interface Card Class X(A) |
| AX-RL8 | 8-Way Relay Output Card (Programmable) |
| AX-UCM3 | Advanced Contact-ID and SSIA Digital dialler, requires AX-SEB2 |
| AX-SEB2 | Serial Expansion Board for use with AX-UCM3 |

* For grey enclosure, add the suffix "G" to the part number.

** Refer to individual Axis AX module data sheets for peer to peer network and peripheral bus optional modules.

Check if this document is up to date | Give us feedback

9564 Yellowhead Trail NW, Edmonton AB, T5G 0W4, Canada T: 1 (866) 462-7100 E: info@harding-tech.com W: www.harding-tech.com

As our policy is one of constant product improvement the right is therefore reserved to modify product specifications without prior notice.